

Collision Avoidance System CAS-M light

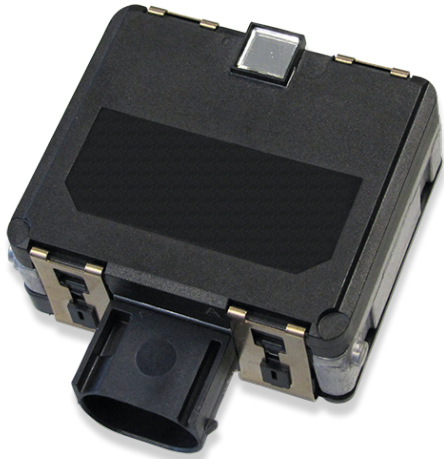

- ▶ Radar sensor with integrated logic
- ▶ Warning for overtake situations
- ▶ Easy system adaptation
- ▶ Universal CAN interface for various displays
- ▶ Visualization via display LEDs

The collision avoidance system CAS-M light helps the driver to focus on the track and warns him if a car is approaching from behind. The system provides information about relative speed and distance of the closest vehicle on the CAN bus. An additional display with CAN bus interface is required (e.g. DDU 9). The information is based on a Bosch radar sensor which contains a FMCW radar transceiver operating in the frequency range of 76.0 - 77.0 GHz. Targets in front of the sensor are reflecting the radar signal and the relative speed and distance is determined via Doppler-effect and beat frequency. The benefit is even more increased during darkness or in bad weather conditions. The system interface is very intuitive and adaptable to the drivers liking.

Application

Operating temperature	-40 to 85°C
Storage temperature	-20 to 95°C
Range	150 m
Tracks	1 Object (nearest)
Interface	CAN
CAN rate	500 kbaud or 1 Mbaud
CAN update rate	50 Hz
Horizontal field of view Radar	85° from 0 to 29 m 70° from 29 to 46 m 50° from 46 to 73 m 42° from 73 to 78 m 20° from 78 to 95 m

Technical Specifications

Mechanical Data

Weight of radar sensor MRR	199 g
Size	60x70x32 mm
Protection Classification	IP 6K6K (DIN 40 050) IP 6K7 (DIN 40 050)
Max. vibration	Randome vibration aeff = 30.8 m/s ² , 3x8 h (according ISO/DIS 16750-3)

Electrical Data

Supply voltage	6.5 to 18 V
An external fuse has to be provided (rec. 10 A).	
External overvoltage protection is required (internal overvoltage protection up to 35 V).	
Reverse polarity voltage protection	-14 V max. t ≤ 60 sec

Connectors and Wires

Mating connector	F037.B00.168-01
Pin 1	GND
Pin 2	CAN-H
Pin 3	CAN-L
Pin 4	n.c.
Pin 5	n.c.
Pin 6	n.c.
Pin 7	n.c.
Pin 8	V+

Installation Notes

The system includes a radar sensor and a detailed user manual.

Ordering information for suitable wiring looms for the different CAS-M light packages are specified in the user manual.

The system needs to be connected to the vehicle CAN bus (connection to display needed) and supplied with 12 V from the supply system on board.

The rear unit must be mounted 90° to the vehicles vertical and horizontal axis and within ± 200 mm of the vehicle lateral center-line.

Mounting distance of radar over ground: 300 to 1,000 mm

To achieve the expected performance from the radar sensor, it must have a clear and unobstructed view. There should be no material over the radar sensor and the sensor should be allowed a clear 180-degree field of view.

The system needs yaw rate and vehicle speed information.

Cat 6 A standard for Gigabit Ethernet.

See CAS-M light in action on <http://youtu.be/EzpSy-eJRi4>

Legal

The CAS-M 3 radar sensor is based on the Bosch Engineering MRRe14HBW radar sensor. The MRRe14HBW is frequency certified for the following countries:

Country
Austria, Belgium, Bulgaria, Croatia, Cyprus, Czech Republic, Denmark, Estonia, Finland, France, Germany, Greece, Hungary, Ireland, Italy, Latvia, Lithuania, Luxembourg, Malta, Netherlands, Poland, Portugal, Romania, Slovakia, Slovenia, Spain, Sweden, Iceland, Liechtenstein, Norway, Switzerland
USA
Canada

Country
Japan
Australia
New Zealand
United Kingdom

If the MRRe14HBW and hence the CAS-M 3 radar sensor SCU is not operated within this context, it lies within the customer’s responsibility to ensure compliance of the application with national regulations and standards, e.g., electromagnetic compatibility and radio spectrum matters.

Link to the up-to-date EU Declaration of Conformity DoC:

<http://eu-doc.bosch.com>

(Please enter the model MRRe14HBW on which CAS-M sensors are based on to find the correct DoC in the database.)

Legal Restrictions

The sale of this product in Mexico is prohibited. Due to embargo restrictions, sale of this product in Russia, Belarus, Iran, Syria, and North Korea is prohibited.

Ordering Information

CAS-M light (500 kbaud)

Order number **F02U.V02.021-01**

CAS-M light (1 Mbaud)

Order number **F02U.V02.220-01**

CAS-M light incl. Display DDU 9 (500 kbaud)

Order number **F02U.V02.591-01**

CAS-M light incl. Display DDU 9 (1 Mbaud)

Order number **F02U.V02.592-01**

Dimensions

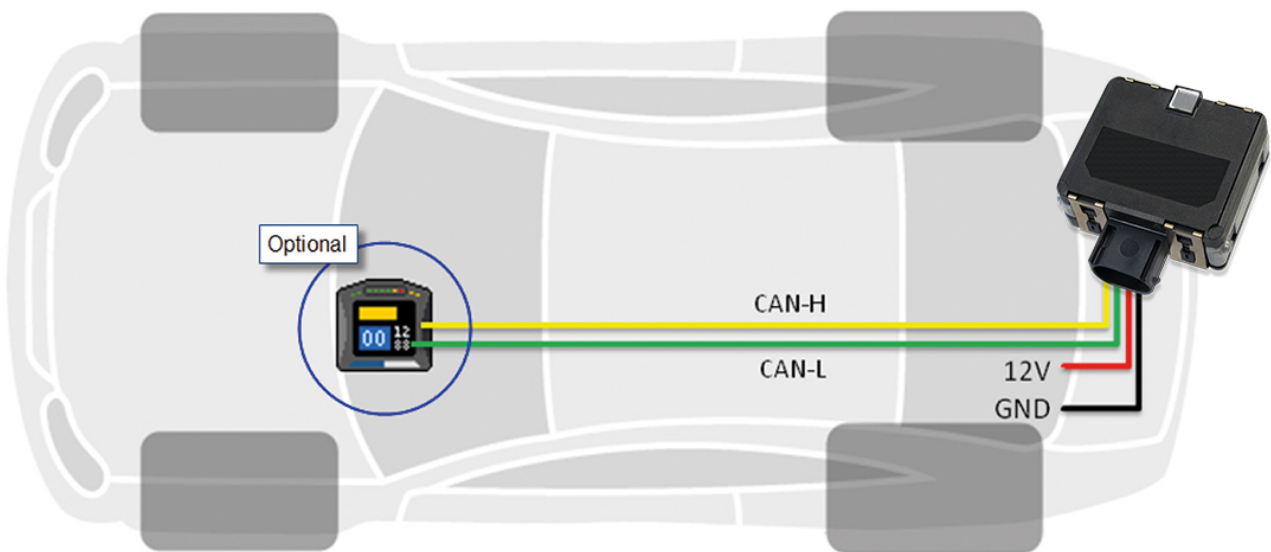

Wiring schematic

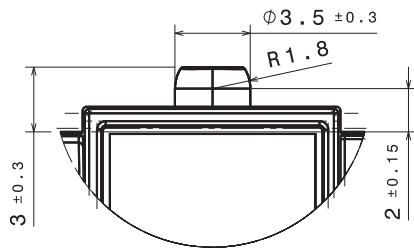

Detail A

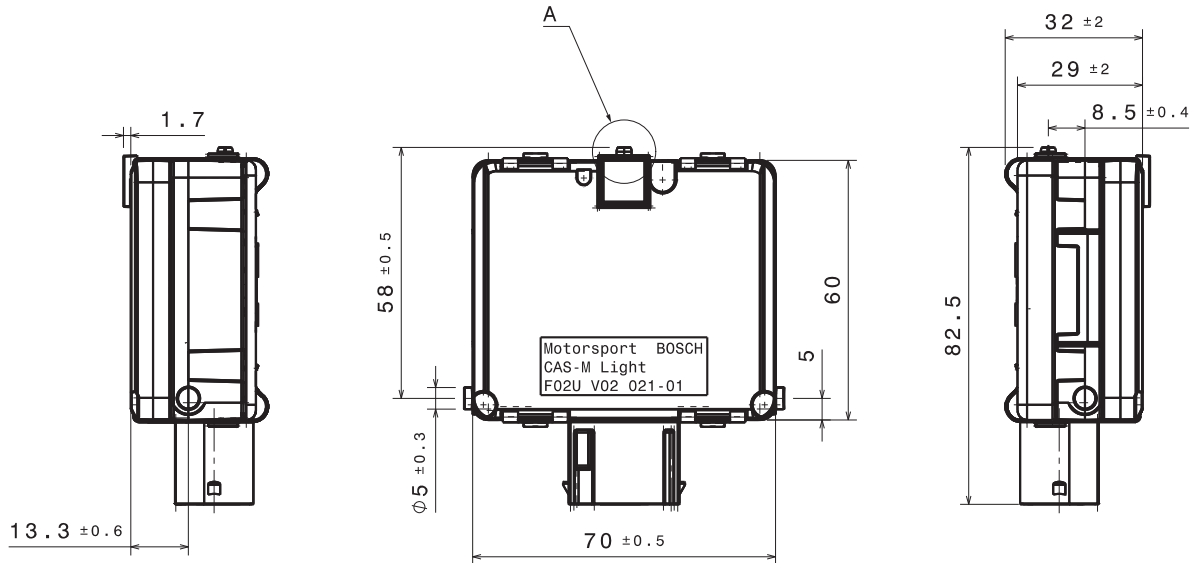
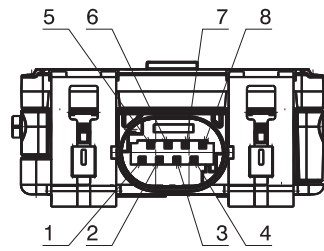

Right view

Front view

Left view

Dimensions

Represented by:

Europe:
 Bosch Engineering GmbH
 Motorsport
 Robert-Bosch-Allee 1
 74232 Abstatt
 Germany
 Tel.: +49 7062 911 9101
 Fax: +49 7062 911 79104
 motorsport@bosch.com
 www.bosch-motorsport.de

North America:
 Bosch Engineering North America
 Motorsport
 38000 Hills Tech Drive
 Farmington Hills, MI 48331-3417
 United States of America
 Tel.: +1 248 876 2977
 Fax: +1 248 876 7373
 motorsport@bosch.com
 www.bosch-motorsport.com

Asia-Pacific:
 Bosch Engineering Japan K.K.
 Motorsport
 18F Queen's Tower C, 2-3-5 Minato
 Mirai Nishi-ku, Yokohama-shi
 Kanagawa 220-6218
 Japan
 Tel.: +81 45 650 5610
 Fax: +81 45 650 5611
 www.bosch-motorsport.jp

Australia, New Zealand and South Africa:
 Robert Bosch Pty. Ltd
 Motorsport
 1555 Centre Road
 Clayton, Victoria, 3168
 Australia
 Tel.: +61 (3) 9541 3901
 motor.sport@au.bosch.com