

Steering Wheel Angle Sensor LWS



- ▶ Steering Wheel Angle: $\pm 780^\circ$
- ▶ Angular Speed: 0 to 1,016°/s
- ▶ 500 kbaud CAN-output

This sensor is designed to measure rotational movement and angular speed, e.g. steering wheel angle and steering wheel speed.

In order to achieve this, the sensor is using the giant magneto resistive (GMR) effect. The detection of the absolute angle is realized by means of toothed measuring gears with different ratio including small magnets. Corresponding GMR elements that change their electrical resistance according to the magnetic field direction detects the angle position of the measuring gears.

The measured voltages are A/D converted and a microcontroller performs the angle calculations. The steering angle and the steering angle speed are provided on a CAN-interface.

Application

Steering wheel angle	$\pm 780^\circ$
Angular speed	0 to 1,016°/s
Operating temperature range	-40 to 85°C

Technical Specifications

Mechanical Data

Weight	Approx. 34 g
Size	83 x 60 x 21.35 mm
Protection class	IP5K0

Electrical Data

Power supply	7 to 16 V
Max input current	< 150 mA
CAN speed	500 kbaud

CAN Message

CAN ID 01 0x2B0 LWS_Standard

Byte	Value / Bit			
	7/6/5/4/3	2	1	0
0	LWS_ANGLE			
1	LWS_ANGLE			
2	LWS_SPEED			
3	Reserved	TRIM	CAL	OK
4	Reserved			

CAN ID 02 0x7C0 LWS_Config

Byte	Value / Bit			
	7/6/5/4/3	2	1	0
0	Reserved	CCW		
1	Reserved			

Truth Table

TRIM	OK	CAL	ANGLE	SPEED	Sensor state
1	1	1	Value	Value	Sensor is calibrated and sensor information is valid.
1	1	0	7FFFh	Value	Sensor is not calibrated, speed information is valid.
1	0	0	7FFFh	FFh	Sensor is in failure mode, sensor information is not valid.
0	0	0	7FFFh	FFH	Sensor is in failure mode, sensor information is not valid.

Other combinations for TRIM, OK and CAL are not valid.

Signal Overview

OK	Failure status
1	Sensor information valid

OK	Failure status
0	Sensor information invalid, an internal sensor fault occurred
CAL	Calibration status
1	Sensor calibrated
0	Sensor not calibrated
TRIM	Trimming Status
1	Sensor trimmed
0	Sensor not trimmed, this is handled as a sensor failure (OK = 0)
CCW	Command code word
3h	Sets the signal LWS_Angle to 0°
5h	Resets the calibration status of the angle

Characteristics

Steering Wheel Angle

Measuring range	± 780°
Absolute physical resolution	0.1°
Nonlinearity	± 2.5°
Hysteresis	0 to 5°

Angular Speed

Measuring range	0 to 1,016°/s
Over range limit	± 2,500°/s
Absolute physical resolution	4°/s

Connectors and Wires

Connector	Bosch 7 pole
Mating connector	F02U.B00.656-01
Pin 1	Gnd
Pin 2	12 V
Pin 3	CAN High
Pin 4	CAN Low
Pin 5	Not connected
Pin 6	Not connected

Pin 7	Not connected
-------	---------------

CAN Parameters

Byte order	LSB (Intel)
CAN speed	500 kbaud
CAN update rate	100 Hz / 10 ms

Installation Notes

The LWS can be connected directly to most control units and data logger systems via CAN bus.

Please avoid abrupt temperature changes.

Please ensure that the environmental conditions do not exceed the sensor specifications.

Please find further application hints in the offer drawing.

A zero adjustment is needed before using the sensor for the first time. To do so, reset the calibration with CCW = 5h. After resetting the calibration, a new calibration needs to be started with CCW = 3h. The sensor is now newly calibrated and can be used immediately.

Zero the sensor after every assembly.

Safety Note

The sensor is not intended to be used for safety related applications without appropriate measures for signal validation in the application system.

Legal Restrictions

Generally blocked are direct and indirect business involving high risk destinations, including Russia, Belarus, Cuba, Iran, North Korea, Syria, Libya, Afghanistan, and certain non-governmental controlled Ukrainian regions. This list may change as geopolitics evolve.

Ordering Information

Steering Wheel Angle Sensor LWS

Order number **F02U.V02.894-01**

Dimensions

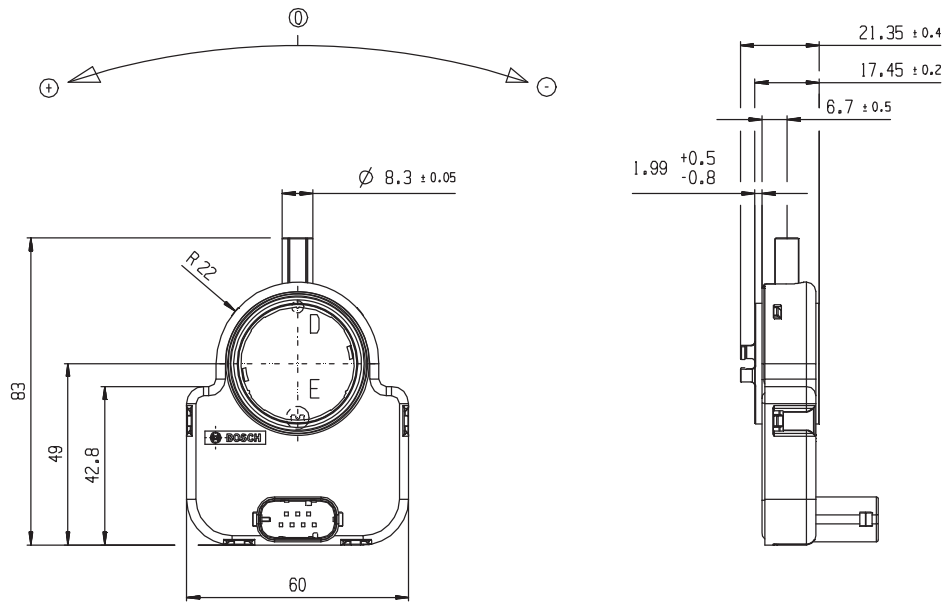

Housing Size

Represented by:

Europe:
 Bosch Engineering GmbH
 Motorsport
 Robert-Bosch-Allee 1
 74232 Abstatt
 Germany
 motorsport@bosch.com
 www.bosch-motorsport.de

North America:
 Bosch Engineering North America
 Motorsport
 38000 Hills Tech Drive
 Farmington Hills, MI 48331-3417
 United States of America
 motorsport@bosch.com
 www.bosch-motorsport.com

Asia-Pacific:
 Bosch Engineering Japan K.K.
 Motorsports Department
 1-9-32 Nakagawachuo, Tsuzuki-ku
 Yokohama-shi
 Kanagawa, 224-8601
 Japan
 motorsport@jp.bosch.com
 www.bosch-motorsport.jp

Australia, New Zealand and South Africa:
 Robert Bosch Pty. Ltd
 Motorsport
 1555 Centre Road
 Clayton, Victoria, 3168
 Australia
 motor.sport@au.bosch.com
 www.bosch-motorsport.com.au