

Ignition Module IM 4

This ignition module IM is an external ignition power stage capable of supplying up to four non-transistorized ignition coils.

The IM input signal should be supplied by an ECU with ignition signal outputs in the range of 10 to 20 mA (e.g. MS 4 Sport/MS 4.4 Sport).

The IM unit combines the robustness of a high quality production part with good electrical performance to provide an ideal solution for adapting non-transistorized coils to an ECU without internal ignition driver stages.



Application	
Primary current	≤ 8.5 A
Clamp voltage	380 V ±30 V
Operating temperature range @ measuring point	-40 ... 120 °C
Storage temperature range	-40 ... 130 °C
Max. vibration	400 m/s ² @ 5 ... 2,500 Hz

Electrical Data	
U _{Batt} typical	13.5 V
Voltage supply	6 ... 16.5 V
I _B high active on	min. 10 mA
I _B low off	0 mA
I _B	10 ... 22 mA
I _C typical	< 8.5 A
I _C max. @ T _U < 120 °C	< 10 A
U _{CE Satt} @ I _C = 5 A	< 3 V
U _{CE Satt} @ I _C max	< 9 V

Mechanical Data	
Size	70.5 x 68 x 20 mm
Weight w/o wire	54 g
Mounting	2 x M4 screws with spring washer

Characteristic	
Characteristic dwell time	see characteristic dwell time from the ignition coil used
Internal transistor	triple Darlington

Electronic circuit for connecting the ignition module IM 4

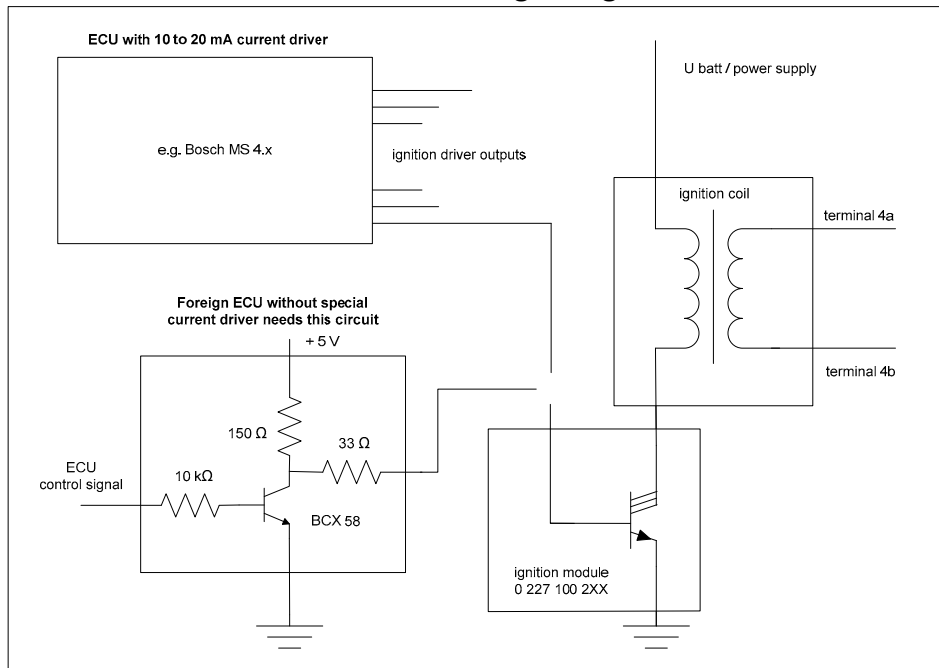

Connectors

Connector 1 Four Pin Connector

Connector	Bosch Jetronic 4-pin
Mating connector	D 261 205 351-01
Pin 1	Collector Transistor 4
Pin 2	Collector Transistor 3
Pin 3	Collector Transistor 2
Pin 4	Collector Transistor 1

Connector 2 Five Pin Connector

Connector	Bosch Jetronic 5-pin
Mating connector	D 261 205 352-01
Pin 1	Basis Transistor 1
Pin 2	Basis Transistor 2
Pin 3	Gnd
Pin 4	Basis Transistor 3
Pin 5	Basis Transistor 4

Application Hint

The ignition module 4 can be used with: Coils 2x2, 3x2, P35, P35-T and PS or comparable coils.

Please ensure that the connectors are safe from water.

The IM has to be mounted onto a cooling body. The mounting surface needs a planarity of 0.2 mm.

A heat conductive paste has to be used.

This ignition module is designed for use with engine control units which have no integrated ignition transistor.

Please observe the specified limit values.

Part Number

Ignition Module IM 4 **0 227 100 211**



Dimensions IM 4

