

Pressure Sensor Combined PST-F 1



- ▶ Pressure: 0 to 10 bar
- ▶ Temperature: -40 to 150°C
- ▶ Power supply: 5 V
- ▶ Weight: 38 g

This sensor is designed to measure relative gasoline pressure and gasoline temperature in port injection systems.

The pressure measurement of the sensor is by means of a piezoresistive element which is acted on by a silicon diaphragm in contact with the fluid being measured. The reference (relative) pressure is provided via an opening in the sensor housing and acts on the active upper side of the silicon diaphragm.

Application

Application 1	0 to 10 bar (rel)
Application 2	-40 to 150°C
Reference	Relative
Max. pressure	20 bar max 15 min
Burst pressure (static)	40 bar
Operating temp. range	-40 to 150°C (160°C max 250 h)
Storage temp. range	-30 to 60°C
Fuel compatibility	Engine oils, most gasoline and Diesel fuels
Max. vibration	80 m/s ² at 20 to 260 Hz 60 m/s ² at 260 to 520 Hz
Vibration testing	according to DIN EN ISO 60068-2-6 (2008-10)
Amplitude of deflection	s=0,35 mm at 70 to 147 Hz
Amplitude of acceleration a	a=300 m/s ² at 147 to 2,000Hz

Technical Specifications

Mechanical Data

Male thread	M10x1
Weight without wire	38 g
Wrench size	27 mm
Installation torque	24 Nm
Sealing	Sealed cone

Electrical Data

Power supply U_s	4.75 to 5.25 V
Max power supply U_s max	16 V (18 V, 1 h max)
Full scale output U_A	0.5 to 4.5 V U_s ratiometric
Current I_s	12.5 mA

Characteristic 1

Response time U_{out} when U_s is switched-on $t_{10/90}$	2.0 ms
Jump response time to pressure changes U_{out}	0.8 ms
Compensated range	-40 to 150°C
Tolerance (FS) at U_s	+/-1.2 % at 0 to 100°C

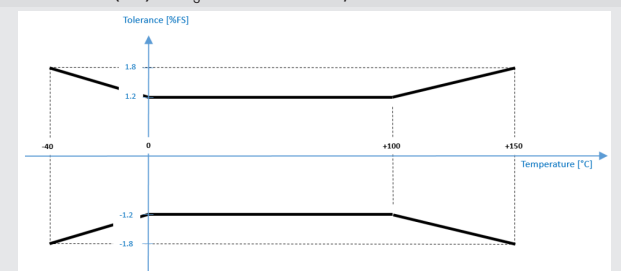

Sensitivity	400 mV/bar at $U_s = 5$ V
Offset	500 mV at $U_s = 5$ V

Characteristic 2

Response time t10/90	9 s (meas. in oil, 20 to 100°C)
T [°C]	R [Ohm]
-40	44,864
-30	25,524
-20	15,067
-10	9,195
0	5,784
10	3,740
20	2,480
30	1,683
40	1,167
50	824
60	594
70	434.9
80	323.4
90	244
100	186.6
110	144.5
120	113.3
130	89.9
140	71.9
150	58.1

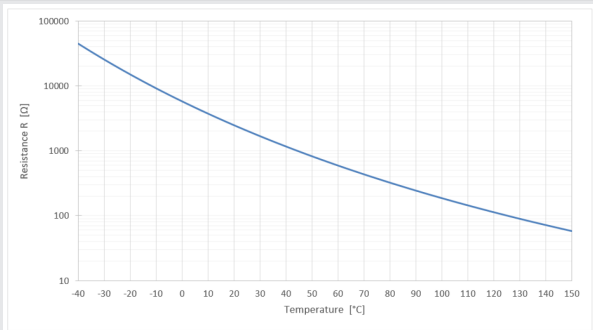

Connectors and Wires

Connector	Bosch Trapezoid
Mating connector	F02U.B00.751-01
Pin 2	Pressure Signal
Pin 3	Power Supply
Pin 4	Ground
Pin 5	Temperature Signal

Installation Notes

The sensor can be connected directly to most control units.
 For temperature measurement please use a pull-up resistor with an optimal value of 4.6 kOhm.
 The sensor has a protection for overvoltage, reverse polarity and short-circuit.
 Please find further application hints in the offer drawing and free download of the sensor configuration file (*.sdf) for the Bosch Data Logging System at our homepage.

Safety Note

The sensor is not intended to be used for safety related applications without appropriate measures for signal validation in the application system.

Legal Restrictions

Generally blocked are direct and indirect business involving high risk destinations, including Russia, Belarus, Cuba, Iran, North Korea, Syria, Libya, Afghanistan, and certain non-governmental controlled Ukrainian regions. This list may change as geopolitics evolve.

Ordering Information

Pressure Sensor Combined PST-F 1
 Order number **0261.544.01F**

Dimensions

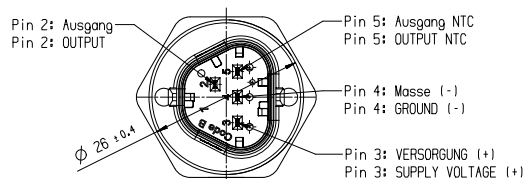
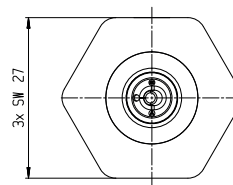
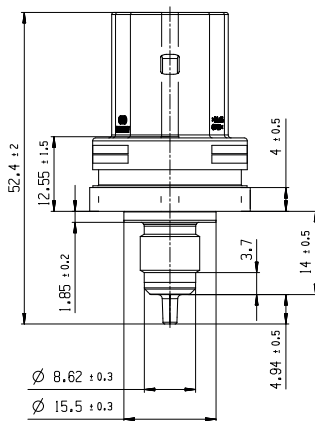

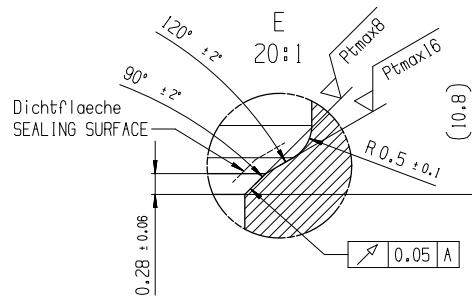
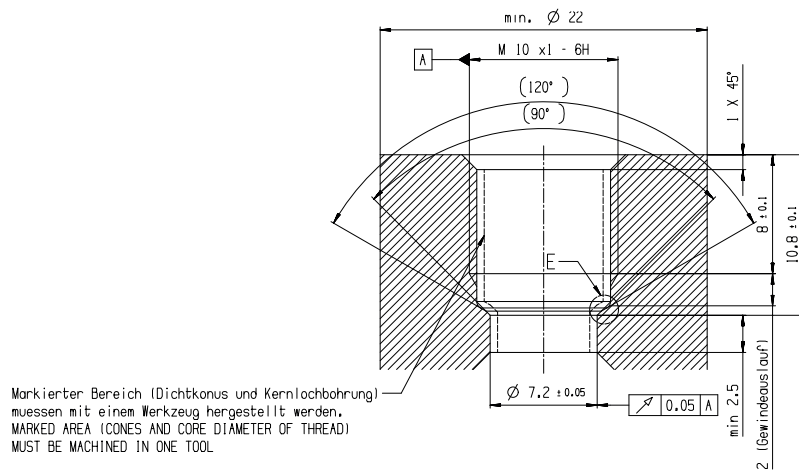

Represented by:

Europe:
 Bosch Engineering GmbH
 Motorsport
 Robert-Bosch-Allee 1
 74232 Abstatt
 Germany
 motorsport@bosch.com
 www.bosch-motorsport.de

North America:
 Bosch Engineering North America
 Motorsport
 38000 Hills Tech Drive
 Farmington Hills, MI 48331-3417
 United States of America
 motorsport@bosch.com
 www.bosch-motorsport.com

Asia-Pacific:
 Bosch Engineering Japan K.K.
 Motorsports Department
 1-9-32 Nakagawachuo, Tsuzuki-ku
 Yokohama-shi
 Kanagawa, 224-8601
 Japan
 motorsport@jp.bosch.com
 www.bosch-motorsport.jp

Australia, New Zealand and South Africa:
 Robert Bosch Pty. Ltd
 Motorsport
 1555 Centre Road
 Clayton, Victoria, 3168
 Australia
 motor.sport@au.bosch.com
 www.bosch-motorsport.com.au